

Product Features



- Aluminium die cast housing duly powder coated.
- Metal Clad PCB's.
- Long life and better thermal management.
- High efficacy LED.
- Uniform and optimum light output and energy savings.
- Technically advanced Optic lens with high precision light output.
- Higher PF, Lower THD and Surge Protection.



Electrical Specification	Rated Voltage (V)	220-240Vac
	Operating Voltage Range (V)	140-300Vac
	Operating Frequency (Hz)	50 +/-3%
	Power Factor	> 0.95
	Driver Efficiency (%)	> 87
	A-THD	< 10
	System Power Consumption (W)± 10%	30/50/70/90/100/120/200W
	Inbuilt Surge Protection (kV)	5KV
	Electrical Insulation Class	Suitable for Class I
Surge Protection (kV)(Inline SPD)	Optional (10KV OR 20KV)	
Optical Specification	Light Source	LED
	Typ. Fixture Efficacy (LM/W)	110
	Color Temperature (K)	CDL / NDL / WDL
	CRI	70
	Diffuser / Optical material	Polycarbonate
	Beam Angle options	60°
Other Specification	Operating Ambient Temperature (°C)	0°C to + 50°C
	Housing	Powder coated Aluminum die cast
	Mounting Arrangement	Cradle mounted
	IP rating	IP65

Model No.

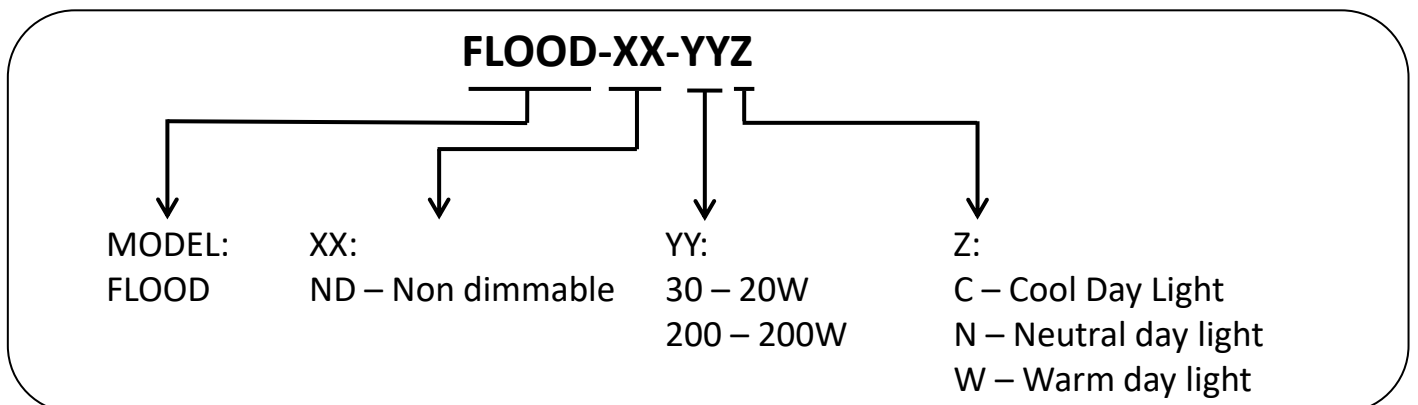

All features, functionality and other product specifications are subject to change without notice or obligation.